

SEBASTIAN CASEWORK

OVERVIEW OF THE STANDARD LINE OF SEBASTIAN CASEWORK

WITH REFERENCE TO ARCHITECTURAL SPECIFICATION 11470 (SEE SECTION 7 IN THIS CATALOG), IT IS VERY EVIDENT THAT SEBASTIAN CASEWORK IS BEAUTIFULLY CRAFTED, HEAVY-DUTY CABINETRY. THE STANDARD LINE OF SEBASTIAN CASEWORK CONTAINS MANY TYPES OF COUNTER TOPS, WALL AND BASE CABINETS.

CATALOG NUMBERS

FOR EASE OF SCHEDULING, EACH ITEM OF CASEWORK IS ASSIGNED A CATALOG NUMBER, FOR EXAMPLE:

"SBC-363629" IS A BASE CABINET WITH A DRAWER, AN ADJUSTABLE SHELF AND TWO DOORS.

THE CABINET IS 36" WIDE x 36" HIGH (WITH BASE AND COUNTER TOP), AND 29" DEEP (30" WITH 30" C TOP). ALL ARE OVERALL DIMENSIONS.

CABINET BASES ARE 4" HIGH AND COUNTER TOPS ARE 1-1/4" THICK. THE 4" HIGH BACKSPLASH IS NOT INCLUDED IN THE HEIGHT DIMENSION.

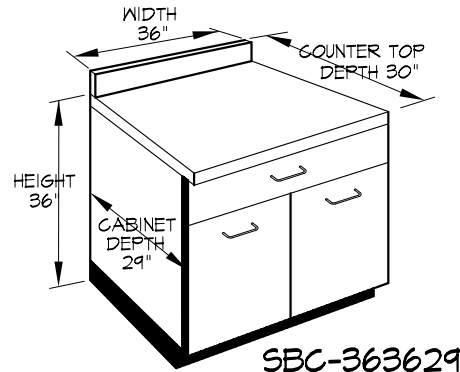

WALL CABINETS

WIDTHS OF WALL CABINETS VARY FROM 15" TO 36" IN INCREMENTS OF 3." WALL CABINETS ARE OFFERED IN TWO HEIGHTS: 18" AND 30." WALL CABINETS WITH DOORS ARE 13" DEEP & WITHOUT DOORS ARE 12" DEEP. CABINETS 18" HIGH HAVE ONE ADJUSTABLE SHELF AND CABINETS 30" HIGH HAVE TWO ADJUSTABLE SHELVES. CABINETS WIDER THAN 24" HAVE DOUBLE DOORS. LOCKS WITH MASTER KEY ARE ORDERED SEPARATELY.

BASE CABINETS

WIDTHS OF BASE CABINETS VARY FROM 15" TO 48" IN INCREMENTS OF 3." WALL CABINETS ARE OFFERED IN THREE HEIGHTS: 30" (DESK HEIGHT), 34" (HEIGHT FOR HANDICAPPED STUDENTS) AND 36." BASE CABINETS MAY BE ORDERED IN ONE OF THREE DEPTHS: 15" WITH DOORS (OR 14" WITHOUT DOORS), 24" WITH DOORS (OR WITHOUT DOORS 23") AND 29" WITH DOORS (OR 28" WITHOUT DOORS). CABINETS WITHOUT DRAWERS HAVE TWO ADJUSTABLE SHELVES. CABINETS WIDER THAN 24" HAVE DOUBLE DOORS. LOCKS WITH MASTER KEY ARE ORDERED SEPARATELY. CABINET BASES ARE SUPPLIED DETACHED MAKING IT EASIER TO LEVEL THE BASE BEFORE THE CABINETS ARE PLACED IN POSITION. WHEN APPROPRIATE CABINET BASES ARE SUPPLIED TO HOLD SEVERAL CABINETS TO SPEED INSTALLATION.

COUNTER TOPS

COUNTER TOPS VARY ON WIDTH UP TO 12 FEET IN LENGTH. ALL COUNTER TOPS ARE 1-1/4" THICK. THERE ARE THREE DEPTHS: 17" WIDE (FOR 15 OR 14" DEEP CABINETS), 25" WIDE (FOR 24 OR 23" DEEP CABINETS) AND 30" WIDE (FOR 29 OR 28" CABINETS). EACH COUNTER TOP IS SUPPLIED WITH A 4" HIGH BACKSPLASH. ENDSPLASH UNITS ARE ORDERED SEPARATELY. ISLAND COUNTER TOPS ARE FINISHED ON 4 SIDES AND ARE AVAILABLE UPON REQUEST.

FINISHES (ANY WILSON ART LAMINATE MAY BE SPECIFIED WITHOUT ADDITIONAL CHARGE))

DARKROOM STANDARD: COUNTER TOPS - NORTH SEA; CABINETS - PLATINUM

PRINTMAKING STANDARD: COUNTER TOPS - FROSTY WHITE; CABINETS - PLATINUM

COUNTER TOP ALTERNATE CHOICES: TEMPERED GLASS ON WHITE LAMINATE; WHITE HARD WOOD; EPOXY RESIN TOP WITH OR WITHOUT A MARINE LIP.



SEBASTIAN DARKROOM PRODUCTS™ DIVISION OF CALIFORNIA STAINLESS MFG.

Unique, Innovative & Engineered to Work
TOLL FREE (888) 712-7035 FAX (805) 484-1030

calstainless@aol.com

www.sebastiandarkroomprod.com